



People who serve, products that solve™

How Smart is Your Toaster?



ITQ-1000-1C

Hatco's New Intelligent Toast-Qwik® allows the operator to toast multiple products at the touch of the button, changing easily from bagels to croissants to Texas toast to hash browns, as well as melting cheese and finishing smaller food products. The unit can easily take the place of the current toasting platform and add versatility and future menu expansion along with energy efficiency and cost savings.

- The conveyor can operate in four different modes:
 1. **Continuous Through Put** - like a standard conveyor toaster
 2. **Single Product Mode** - a single product can be toasted and then the conveyor stops
 3. **In and Out Mode** - the product is drawn into the chamber, pauses for a programmed amount of time, and then backs out of the chamber
 4. **In, Pause, and Continuous Through Put** - the product is drawn into the chamber, pauses for a programmed amount of time, and then continues through the chamber
- Hatco's patented ColorGuard sensing system monitors and adjusts conveyor speed and temperature during high usage periods to ensure toast color uniformity
- Using Hatco's Spot-On® technology, the toaster senses when product is placed on the conveyor and activates the unit
- The ability to hold up to eighteen product settings
- USB port located on the front allows for easy transfer of information such as program changes and product usage information

Spot-ON®
Technology



For more information, contact Hatco at: (800) 558-0607 • (414) 671-6350 • www.hatcocorp.com



INTELLIGENT TOAST-QWIK® CONVEYOR TOASTERS

Models: ITQ-1000-1C

ITEM#

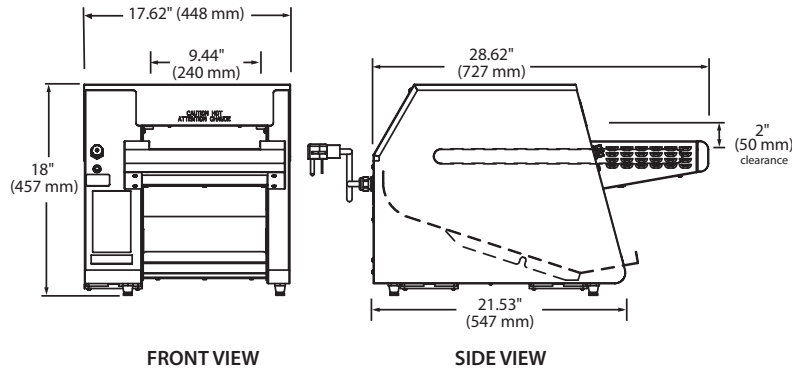

Model ITQ-1000-1C

SPECIFICATIONS

Model†	Volts	Watts	Amps	Cap. per minute†	Shipping Weight
ITQ-1000-1C®	208-240	3230-4300	15.5-17.9	17	68 (31 kg)

® Unit is designed to operate on supply voltages between 208V and 240V

† Toasting capacity may vary by product. Toasting of coated products not recommended.

DIMENSIONS

ITQ-1000-1C: 17.62"W x 28.62"D x 18"H (448 x 727 x 457 mm).

OPENING DIMENSIONS

ITQ-1000-1C: 2"H (50 mm).

VOLTAGE

ITQ-1000-1C: 208-240 volt, 60 Hz, single phase.

CORD LOCATION

Left center on back of unit.

Accessories

- Food paddle

PRODUCT SPECS

Conveyor Toaster

The electric Intelligent Toast-Quick® Conveyor Toaster shall be a Hatco Model ... as manufactured by the Hatco Corporation, Milwaukee, WI 53234 U.S.A.

The toaster shall have the capacity to toast up to ... pieces per minute and it shall be rated at ... kW, ... volts, single phase.

The toaster shall be of stainless steel design and shall include a front mounted control panel with state-of-the-art electronic top

and bottom heat controls, Spot-On® technology, ColorGuard sensing system (patented), variable speed control, power save mode with indicator light and a toast collector pan.

The toaster will have metal sheathed heating elements and factory attached UL listed cord and plug.

One year on-site parts and labor warranty, plus one additional year parts-only warranty on all metal sheathed heating elements, with 24/7 service (U.S. and Canada only).

HATCO CORPORATION P.O. Box 340500 Milwaukee, WI 53234-0500 U.S.A. • (800) 558-0607 • (414) 671-6350
Fax (800) 543-7521 • Int'l. Fax (414) 671-3976 • www.hatcocorp.com • E-mail: equipsales@hatcocorp.com

Form No. ITQ-1000-1C Spec Sheet

Printed in U.S.A.
February 2014